

AL-90

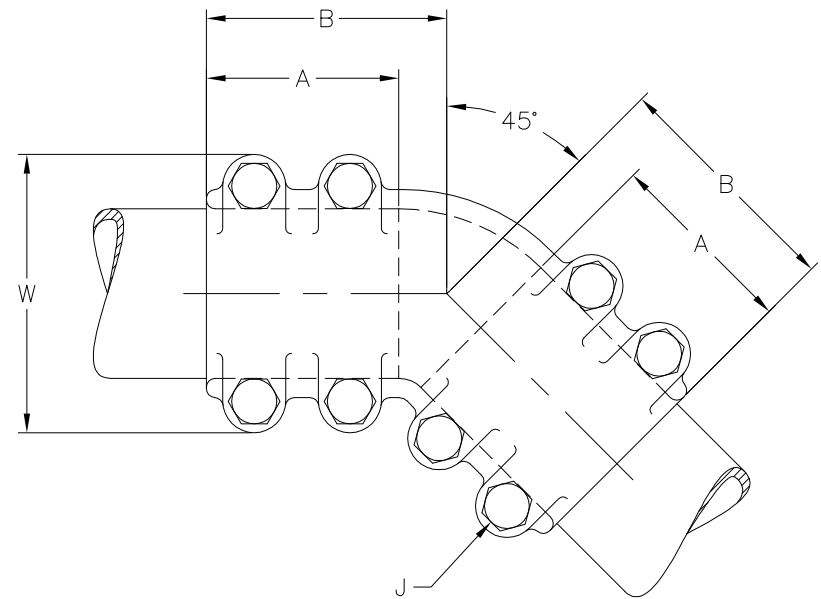

AL-45

NOTES:

1. MATERIAL: CASTINGS – 356-T6 ALUMINUM ALLOY  
HARDWARE – ALUMINUM ALLOY
2. DIMENSION IN INCHES
3. CONTACT SEALANT IS RECOMMENDED

57443	9/8/14	JLB	JLB
EC #	DATE	CHG BY	RESP ENG
DESC OF DWG: UPDATE DRAWING TO AUTOCAD FILE			
REASON(S) FOR CHANGE: --			
DISPOSITION OF MAT'L: --			

ANDERSON\*

CONFIDENTIAL: THIS DRAWING AND ITS CONTENTS ARE CONFIDENTIAL AND THE EXCLUSIVE PROPERTY OF HUBBELL POWER SYSTEMS. NO PUBLICATION, DISTRIBUTION OR COPIES MAY BE MADE WITHOUT THE WRITTEN CONSENT OF HUBBELL POWER SYSTEMS. HUBBELL POWER SYSTEMS UNPUBLISHED ALL RIGHTS RESERVED UNDER THE COPYRIGHT LAWS.

 <b>HUBBELL® POWER SYSTEMS</b>			
TITLE BOLTED ELBOW CONNECTOR TUBE TO TUBE			
SIZE	DWG NO.	CAT / PART / ASSY NO.	REV
C	C-2527	SEE TABLE	05
DO NOT SCALE THIS DRAWING	DRN BY BB	DATE 4/24/59	SHEET 1 of 2

CATALOG NUMBER	IPS SIZE	A	B	J	W
AL-45-0606	0.750	2.500	2.938	0.500	3.000
AL-45-1010	1.000	2.875	3.375	0.500	3.250
AL-45-1212	1.250	3.000	3.563	0.500	3.625
AL-45-1414	1.500	3.375	4.000	0.500	3.813
AL-45-2020	2.000	3.500	4.375	0.500	4.313
AL-45-2424	2.500	3.750	4.750	0.500	4.813
AL-45-3030	3.000	4.125	5.000	0.625	5.813
AL-45-3434	3.500	4.250	5.563	0.625	6.313
AL-45-4040	4.000	4.250	5.688	0.625	6.938
AL-45-5050	5.000	5.000	6.938	0.625	7.938
AL-45-6060	6.000	6.000	7.875	0.625	9.063

CATALOG NUMBER	IPS SIZE	A	B	J	W
AL-90-0606	0.750	2.500	3.938	0.500	3.000
AL-90-1010	1.000	2.750	4.438	0.500	3.250
AL-90-1212	1.250	3.000	4.750	0.500	3.625
AL-90-1414	1.500	3.313	5.000	0.500	3.813
AL-90-2020	2.000	3.563	5.500	0.500	4.313
AL-90-2424	2.500	3.875	5.750	0.500	4.813
AL-90-3030	3.000	4.125	6.375	0.625	5.813
AL-90-3434	3.500	4.375	6.875	0.625	6.313
AL-90-4040	4.000	4.250	7.938	0.625	6.938
AL-90-5050	5.000	5.000	9.000	0.625	7.938
AL-90-6060	6.000	6.000	10.563	0.625	9.063

57443	9/8/14	JLB	JLB
EC #	DATE	CHG BY	RESP ENG
DESC OF DWG SEE PAGE 1 --- --- --- REASON (S) FOR CHANGE: -- DISPOSITION OF MAT'L: --			

ANDERSON®  
CONFIDENTIAL: THIS DRAWING AND ITS CONTENTS ARE CONFIDENTIAL AND THE EXCLUSIVE PROPERTY OF HUBBELL POWER SYSTEMS. NO PUBLICATION, DISTRIBUTION OR COPIES MAY BE MADE WITHOUT THE WRITTEN CONSENT OF HUBBELL POWER SYSTEMS. HUBBELL POWER SYSTEMS UNPUBLISHED. ALL RIGHTS RESERVED UNDER THE COPYRIGHT LAWS.

		HUBBELL® POWER SYSTEMS	
TITLE BOLTED ELBOW CONNECTOR TUBE TO TUBE			
SIZE	DWG NO.	CAT / PART / ASSY NO.	REV
C	C-2527	SEE TABLE	05
DO NOT SCALE THIS DRAWING	DRN BY BB	DATE 4/24/59	SHEET 2 of 2